

With its slim, uncluttered design, Sync is the epitome of compact style. **Sync** offers true direct/indirect lighting distribution and luminous aesthetics with exceptional glare control.

Project: _____
 Location: _____
 Cat.No: _____
 Type: _____
 Line ID: _____ Qty: _____
 Notes: _____

Ordering guide

example: 7406LBCQN087DEW, A1-24

Family	Source	CRI/CCT ¹	Lumens ¹	Optics	Distribution	Run Length	Wiring ²	Voltage	Driver
7406	L			Q					E
7406 Sync Suspended	L LED	A 80CRI/4000K B 80CRI/3500K C 80CRI/3000K	A 6500 lm/4ft C 4600 lm/4ft E 3400 lm/4ft	Q MesoOptics Lens	N Lightguide D 55% Down Kit G 80% Down Kit J 100% Down Kit	04 4ft 08 8ft xx Continuous Run (4ft increments)	7 1cct Dimming E 2cct A/B Dimming (Alt. 4ft sections) M 1cct Dimming + EM Wiring N 1cct Dimming + EM Batt. Pack	D UNV 120-277V 3 347V	E Advance 0-10V (1% Dim)
Finish	Mount Type	Suspension							
W Standard White	A1 Non-accessible ceiling, 0°-15° Slope Mount	24	24"						
T Titanium Silver	A2 T-grid Fixed Position Mount	48	48"						
B Black	A3 Non-accessible ceiling, 0°-90° Slope Mount	96	96"						
C Custom	A5 T-grid 24" Span Mount (non tegular tile only)	144	144"						
	A6-1 T-grid On-grid Mount 15/16" (non tegular tile only)								
	A6-2 T-grid On-grid Mount 9/16" (non tegular tile only)								
	A6-3 T-grid On-grid Mount 9/16" x 5/16" (slot tee & tegular tile)								

1. Nominal values within a range. Down kits reduce output & efficacy. Consult photometry data for color temp, lumens & distribution of chosen configuration.
 2. Not all wiring types are available with all configurations. Consult Ledalite for a complete list of available options

Sync linear suspended

Cross Section View

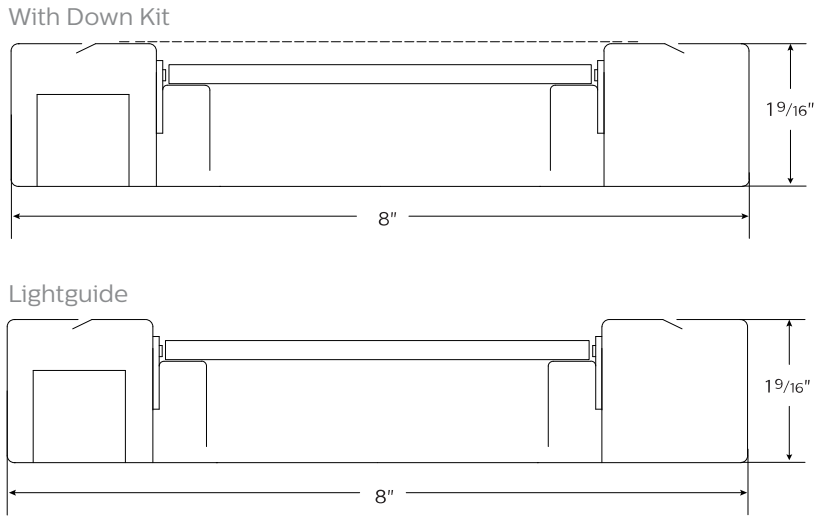

Cross Section View – Endcaps

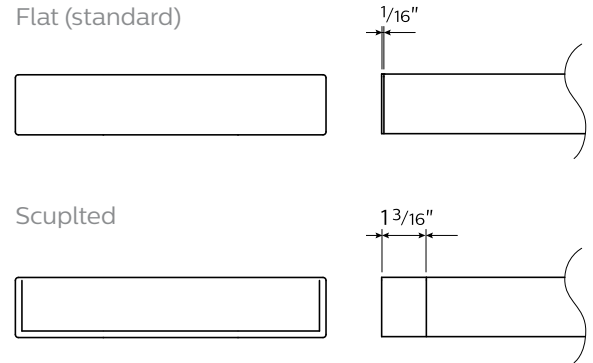

Cross Section View – Optics Details

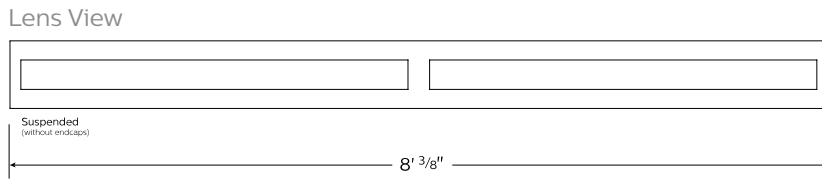

Module Details & Dimensions

Module length excludes end caps. Nominal mounting spacing for individually mounted modules.

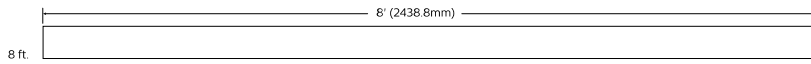
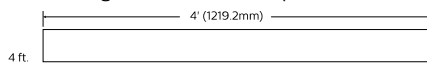

Note: Refer to installation instructions for exact mount.

Sync linear suspended

Specifications

Optical System

The optical system contains arrays of LEDs edge-lighting a low profile light-guide panel, using total internal reflection to homogenize the sources. The microstructured surface of the panel optimizes light extraction to create an efficacious direct/indirect distribution. Light is purified and controlled by MesoOptics film as it passes through a non-glare acrylic lens. Standard distribution is 75% up / 25% down for suspended and 65% up / 35% down for wall mount version.

Endcaps

Diecast aluminum endcaps, available in flat (standard) or sculpted (optional).

Finish

Standard finish is a textured matte powder coat in white, black or titanium silver.

Housing

Precision formed 18 gauge cold-rolled steel.

Weight

Maximum: Suspended 3.75lb/ft & Wall 3.0lb/ft.

Electrical

Factory pre-wired to section ends with quick-wire connectors.

Standard Driver

Advance Xitanium 0-10V, 1-100%. Class 2 rated output. Consult Ledalite for other available drivers.

Standard Battery Pack

Bodine, 90 min, 10W, Class 2 rated output, Emergency lumen output = 10W x luminaire efficacy x 1.1. Typical output: 1100lm.

Lumen Maintenance

LEDs have been tested by the manufacturer in accordance with IESNA LM-80-08. At an ambient temperature of 25°C, the LED lumen maintenance expectation according to IES TM-21-11 is:
L80 (12k) >72,000 hrs (Reported methodology).

Source Color

LEDs rated for color rendering CRI >80 and fixture to fixture color accuracy within 2 SDCM.

Mounting

Tamper-resistant aircraft cable gripper provides unlimited vertical adjustment. Aircraft cable, crimp and cable gripper are independently tested to meet stringent safety requirements.

Joints

Self-aligning joining system with hands-free pre-joining wire access.

Approvals

Certified to UL, CSA and IES standards.

Warranty

Signify indoor professional luminaires 5 year LED warranty: www.signify.com/warranties.

Environment

Rated for dry or damp locations in operating ambient temperatures 0-40°C (32-104°F). Certain luminaire components may be adversely affected by contaminants. Damage caused by sulfur, chlorine, petroleum based solutions or other contaminants are not covered under warranty. Not suitable for natatorium environments.

Sync linear suspended

Photometrics

MesoOptics + Lightguide Distribution (QN)

(Click "PDF" and "IES" text to Download)

Lumen Package	Nominal CRI & CCT	Flux (lm)	Watts (W)	Efficacy (LPW)	CRI	RP-1 VDT	DLC*	Photometry Report	IES File
6500 lm/4ft	80CRI, 4000K	6636	56.5	117.5	83	Critical spaces	Standard	PDF	IES
	80CRI, 3500K	6453	56.7	113.8	82	Critical spaces	Standard	PDF	IES
	80CRI, 3000K	6180	56.9	108.6	84	Critical spaces	Standard	PDF	IES
4600 lm/4ft	80CRI, 4000K	4739	39.2	120.9	83	Critical spaces	Standard	PDF	IES
	80CRI, 3500K	4608	39.4	117.0	82	Critical spaces	Standard	PDF	IES
	80CRI, 3000K	4412	39.5	111.7	84	Critical spaces	Standard	PDF	IES
3400 lm/4ft	80CRI, 4000K	3513	28.3	124.1	83	Critical spaces	Standard	PDF	IES
	80CRI, 3500K	3416	28.4	120.3	82	Critical spaces	Standard	PDF	IES
	80CRI, 3000K	3271	28.5	114.8	84	Critical spaces	Standard	PDF	IES

*DLC is only available wwith Advance 0-10V (1% dim) drivers. EM Batt. Packs are also not available on DLC.

	CANDELA DISTRIBUTION					Flux Lumens
	0	22.5	45	67.5	90	
0	229	229	229	229	229	
5	230	231	233	236	236	23
15	244	250	269	288	295	77
25	261	276	320	361	378	147
35	259	274	315	350	363	193
45	206	210	221	229	232	170
55	137	135	136	140	142	124
65	81	80	82	85	88	82
75	33	34	35	36	36	38
85	6	7	7	7	8	9
90	0	0	0	0	0	
95	99	115	162	226	252	180
105	259	308	458	665	767	502
115	341	397	556	761	862	567
125	350	394	510	645	708	465
135	330	363	422	490	519	331
145	316	338	365	394	406	230
155	309	324	343	352	353	157
165	304	313	323	329	330	91
175	300	303	305	307	308	29
180	299	299	299	299	299	

*Photometric data shown is for 3400 lm/4ft, 3500K, 80 CRI configuration.

COEFFICIENTS OF UTILIZATION (%)													
Pc---	80				70				50				0
Pw---	70	50	30	10	70	50	30	50	30	10	0	0	
RCR													
0	101	101	101	101	90	90	90	70	70	70	25		
1	92	88	85	81	82	79	76	61	59	57	22		
2	84	77	71	67	75	69	64	54	50	48	18		
3	77	68	61	56	68	61	55	47	43	40	16		
4	70	60	53	47	62	54	47	42	38	34	13		
5	64	53	46	40	57	48	41	37	33	29	12		
6	59	48	40	34	52	43	36	34	29	25	10		
7	54	43	35	30	48	38	32	30	26	22	9		
8	50	39	31	26	45	35	28	27	23	19	8		
9	47	35	28	23	42	32	25	25	20	17	7		
10	44	32	25	20	39	29	23	23	18	15	6		

ZONAL LUMEN SUMMARY			
Zone	Lumens	%Fixture	%Lamp
0-30	247	7.2%	7.2%
0-40	440	12.9%	12.9%
0-60	734	21.5%	21.5%
0-90	862	25.2%	25.2%
90-130	1715	50.2%	50.2%
90-150	2277	66.7%	66.7%
90-180	2554	74.8%	74.8%
0-180	3416	100.0%	100.0%

Electrical				
120V: P(W), I(A), THD(%), PF	28.4	0.238	8.0	0.994
277V: P(W), I(A), THD(%), PF	28.4	0.107	11.6	0.962
347V: P(W), I(A), THD(%), PF	N/A	N/A	N/A	N/A

AVG LUMINANCE (cd/m²)			
	0	45	90
0	2222	2222	2222
5	2240	2269	2299
15	2451	2702	2963
25	2794	3426	4047
35	3068	3731	4300
45	2827	3033	3184
55	2318	2301	2402
65	1860	1883	2020
75	1237	1312	1350
85	668	779	891

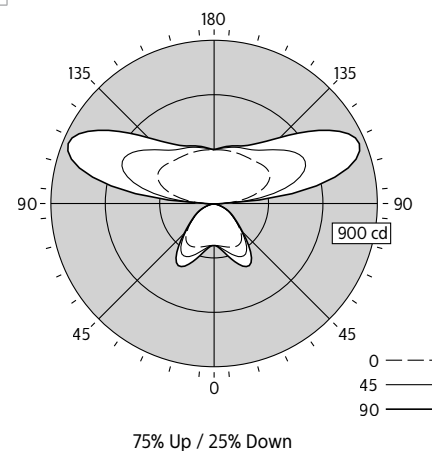

Sync linear suspended

Photometrics

MesoOptics + 55% Down Kit Distribution (QD)

Spacing Criteria: 1.50/1.62

(Click "PDF" and "IES" text to Download)

Lumen Package	Nominal CRI & CCT	Flux (lm)	Watts (W)	Efficacy (LPW)	CRI	RP-1 VDT	DLC*	Photometry Report	IES File
6500 lm/4ft	80CRI, 4000K	5655	56.5	100.1	83	N/A	N/A	PDF	IES
	80CRI, 3500K	5499	56.7	97.0	82	N/A	N/A	PDF	IES
	80CRI, 4000K	5265	56.9	92.5	84	Normal spaces	N/A	PDF	IES
4600 lm/4ft	80CRI, 4000K	4039	39.2	103.0	83	Normal spaces	N/A	PDF	IES
	80CRI, 3500K	3927	39.4	99.7	82	Normal spaces	N/A	PDF	IES
	80CRI, 4000K	3760	39.5	95.2	84	Normal spaces	N/A	PDF	IES
3400 lm/4ft	80CRI, 4000K	2993	28.3	105.8	83	Critical spaces	N/A	PDF	IES
	80CRI, 3500K	2910	28.4	102.5	82	Critical spaces	N/A	PDF	IES
	80CRI, 4000K	2787	28.5	97.8	84	Critical spaces	N/A	PDF	IES

*DLC is only available wwith Advance 0-10V (1% dim) drivers. EM Batt. Packs are also not available on DLC.

CANDELA DISTRIBUTION						Flux
	0	22.5	45	67.5	90	Lumens
0	506	506	506	506	506	
5	508	509	513	516	518	50
15	525	533	564	592	601	161
25	540	560	622	679	699	285
35	512	529	580	616	628	354
45	398	396	401	402	402	310
55	260	254	252	254	256	229
65	153	152	155	159	162	154
75	63	65	66	68	68	72
85	11	13	14	15	15	16
90	0	0	0	0	0	
95	28	35	52	70	77	70
105	122	152	217	309	366	238
115	171	205	282	370	417	282
125	182	208	264	328	355	239
135	175	192	224	255	264	174
145	172	181	200	212	212	124
155	173	176	187	192	191	86
165	172	172	175	176	176	50
175	167	167	167	167	167	16
180	166	166	166	166	166	

*Photometric data shown is for 3400 lm/4ft, 3500K, 80 CRI configuration.

COEFFICIENTS OF UTILIZATION (%)													
Pc---	80				70				50				0
Pw---	70	50	30	10	70	50	30	50	30	10	0	0	
RCR													
0	109	109	109	109	101	101	101	87	87	87	56		
1	100	95	92	88	93	89	86	77	74	72	48		
2	91	84	78	73	84	78	73	68	64	60	41		
3	83	74	67	61	77	69	63	60	55	51	35		
4	76	66	58	52	71	61	55	54	48	44	30		
5	70	59	51	45	65	55	48	48	42	38	26		
6	65	53	45	39	60	49	42	43	37	33	23		
7	60	48	40	34	56	45	38	39	33	29	21		
8	55	43	35	30	52	41	34	36	30	26	18		
9	52	39	32	27	48	37	30	33	27	23	17		
10	48	36	29	24	45	34	27	30	25	21	15		

ZONAL LUMEN SUMMARY			
Zone	Lumens	%Fixture	%Lamp
0-30	495	17.0%	17.0%
0-40	850	29.2%	29.2%
0-60	1389	47.7%	47.7%
0-90	1631	56.1%	56.1%
90-130	830	28.5%	28.5%
90-150	1127	38.7%	38.7%
90-180	1278	43.9%	43.9%
0-180	2910	100.0%	100.0%

Electrical				
120V: P(W), I(A), THD(%), PF	28.4	0.238	8.0	0.994
277V: P(W), I(A), THD(%), PF	28.4	0.107	11.6	0.962
347V: P(W), I(A), THD(%), PF	N/A	N/A	N/A	N/A

AVG LUMINANCE (cd/m²)			
	0	45	90
0	4913	4913	4913
5	4952	4993	5044
15	5275	5663	6041
25	5779	6662	7489
35	6059	6876	7445
45	5458	5501	5515
55	4398	4256	4327
65	3523	3547	3715
75	2348	2466	2544
85	1278	1511	1627

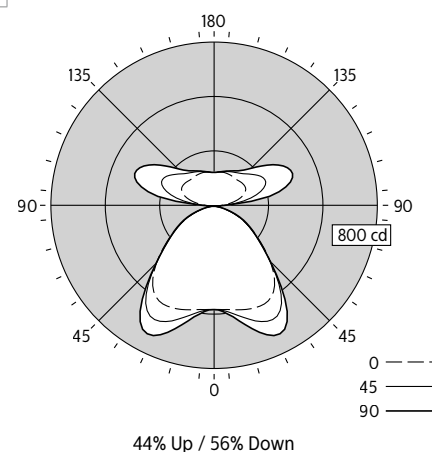

Sync linear suspended

Photometrics

MesoOptics + 80% Down Kit Distribution (QG)

Spacing Criteria: 1.45/1.54

(Click "PDF" and "IES" text to Download)

Lumen Package	Nominal CRI & CCT	Flux (lm)	Watts (W)	Efficacy (LPW)	CRI	RP-1 VDT	DLC*	Photometry Report	IES File
6500 lm/4ft	80CRI, 4000K	5232	56.5	92.6	83	N/A	N/A	PDF	IES
	80CRI, 3500K	5087	56.7	89.7	82	N/A	N/A	PDF	IES
	80CRI, 3000K	4871	56.9	85.6	84	N/A	N/A	PDF	IES
4600 lm/4ft	80CRI, 4000K	3736	39.2	95.3	83	Normal spaces	N/A	PDF	IES
	80CRI, 3500K	3633	39.4	92.2	82	Normal spaces	N/A	PDF	IES
	80CRI, 3000K	3478	39.5	88.1	84	Normal spaces	N/A	PDF	IES
3400 lm/4ft	80CRI, 4000K	2769	28.3	97.8	83	Normal spaces	N/A	PDF	IES
	80CRI, 3500K	2692	28.4	94.8	82	Normal spaces	N/A	PDF	IES
	80CRI, 3000K	2578	28.5	90.5	84	Normal spaces	N/A	PDF	IES

*DLC is only available wwith Advance 0-10V (1% dim) drivers. EM Batt. Packs are also not available on DLC.

CANDELA DISTRIBUTION						Flux
	0	22.5	45	67.5	90	Lumens
0	737	737	737	737	737	
5	739	740	744	749	750	72
15	755	763	798	830	840	227
25	762	781	851	910	932	389
35	707	720	769	802	812	472
45	540	532	527	524	523	410
55	351	342	335	335	337	306
65	208	205	206	211	214	206
75	85	86	87	89	91	95
85	15	17	18	19	19	21
90	0	0	0	0	0	
95	10	11	14	15	15	20
105	56	65	85	98	104	85
115	76	87	111	138	143	109
125	79	87	108	128	129	95
135	75	79	89	105	108	71
145	73	75	79	85	86	50
155	73	75	77	77	77	35
165	73	74	75	76	76	21
175	72	72	72	73	73	7
180	72	72	72	72	72	

*Photometric data shown is for 3400 lm/4ft, 3500K, 80 CRI configuration.

COEFFICIENTS OF UTILIZATION (%)													
Pc---	80				70				50				0
Pw---	70	50	30	10	70	50	30	50	30	10	0	0	
RCR													
0	115	115	115	115	110	110	110	101	101	101	82	70	
1	106	101	98	94	101	97	94	90	87	85	70	60	
2	97	89	83	78	93	86	80	80	75	71	60	51	
3	89	79	72	66	85	76	69	71	65	61	51	44	
4	81	70	62	56	78	68	61	63	57	52	44	39	
5	75	63	55	49	72	61	53	57	50	45	39	34	
6	69	57	49	43	66	55	47	51	45	40	34	30	
7	64	52	43	38	62	50	42	47	40	35	30	27	
8	60	47	39	34	57	46	38	43	36	32	27	24	
9	56	43	35	30	54	42	35	39	33	29	24	22	
10	52	40	32	27	50	39	32	36	30	26	22		

ZONAL LUMEN SUMMARY			
Zone	Lumens	%Fixture	%Lamp
0-30	688	25.6%	25.6%
0-40	1160	43.1%	43.1%
0-60	1875	69.7%	69.7%
0-90	2197	81.6%	81.6%
90-130	309	11.5%	11.5%
90-150	431	16.0%	16.0%
90-180	494	18.4%	18.4%
0-180	2692	100.0%	100.0%

Electrical				
120V: P(W), I(A), THD(%), PF	28.4	0.238	8.0	0.994
277V: P(W), I(A), THD(%), PF	28.4	0.107	11.6	0.962
347V: P(W), I(A), THD(%), PF	N/A	N/A	N/A	N/A

AVG LUMINANCE (cd/m ²)			
	0	45	90
0	7152	7152	7152
5	7199	7250	7301
15	7582	8012	8442
25	8159	9109	9981
35	8372	9114	9621
45	7406	7235	7177
55	5934	5669	5704
65	4770	4722	4914
75	3170	3249	3405
85	1627	1976	2092

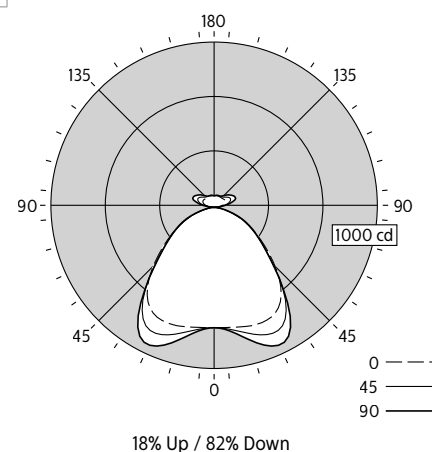

Sync linear suspended

Photometrics

MesoOptics + 100% Down Kit Distribution (QJ)

Spacing Criteria: 1.44/1.50

(Click "PDF" and "IES" text to Download)

Lumen Package	Nominal CRI & CCT	Flux (lm)	Watts (W)	Efficacy (LPW)	CRI	RP-1 VDT	DLC*	Photometry Report	IES File
6500 lm/4ft	80CRI, 4000K	4985	56.5	88.2	83	N/A	N/A	PDF	IES
	80CRI, 3500K	4848	56.7	85.5	82	N/A	N/A	PDF	IES
	80CRI, 3000K	4641	56.9	81.6	84	N/A	N/A	PDF	IES
4600 lm/4ft	80CRI, 4000K	3560	39.2	90.8	83	N/A	N/A	PDF	IES
	80CRI, 3500K	3462	39.4	87.9	82	N/A	N/A	PDF	IES
	80CRI, 3000K	3315	39.5	83.9	84	N/A	N/A	PDF	IES
3400 lm/4ft	80CRI, 4000K	2639	28.3	93.3	83	Normal spaces	N/A	PDF	IES
	80CRI, 3500K	2565	28.4	90.3	82	Normal spaces	N/A	PDF	IES
	80CRI, 3000K	2457	28.5	86.2	84	Normal spaces	N/A	PDF	IES

*DLC is only available wwith Advance 0-10V (1% dim) drivers. EM Batt. Packs are also not available on DLC.

CANDELA DISTRIBUTION						Flux
	0	22.5	45	67.5	90	Lumens
0	877	877	877	877	877	
5	880	880	884	888	889	85
15	896	903	940	974	983	267
25	900	917	989	1049	1071	453
35	830	840	886	918	922	544
45	627	619	611	600	594	473
55	408	400	388	385	385	354
65	242	239	240	243	248	239
75	100	101	102	104	105	112
85	19	20	22	22	22	26
90	0	0	0	0	0	
95	1	1	1	1	0	1
105	1	2	2	3	1	2
115	2	2	3	2	2	2
125	2	3	2	2	2	2
135	2	2	2	3	3	2
145	2	2	2	3	3	2
155	2	2	2	2	3	1
165	2	2	2	1	2	1
175	1	1	1	1	1	0
180	1	1	1	1	1	

*Photometric data shown is for 3400 lm/ 4ft, 3500K, 80 CRI configuration.

COEFFICIENTS OF UTILIZATION (%)													
Pc---	80				70				50				0
Pw---	70	50	30	10	70	50	30	50	30	10	0	0	
RCR													
0	119	119	119	119	116	116	116	111	111	111	100		
1	110	106	102	98	107	103	100	99	96	93	86		
2	101	93	87	82	98	91	86	88	83	79	73		
3	92	83	75	69	90	81	74	78	72	67	63		
4	85	74	66	59	83	72	65	70	63	58	54		
5	78	66	58	51	76	65	57	63	56	51	47		
6	73	60	51	45	71	59	51	57	50	45	42		
7	67	54	46	40	66	54	46	52	45	40	37		
8	63	50	42	36	61	49	41	48	41	36	33		
9	59	46	38	32	57	45	38	44	37	32	30		
10	55	42	35	29	54	42	34	41	34	29	27		

ZONAL LUMEN SUMMARY			
Zone	Lumens	%Fixture	%Lamp
0-30	805	31.4%	31.4%
0-40	1349	52.6%	52.6%
0-60	2176	84.8%	84.8%
0-90	2553	99.5%	99.5%
90-130	8	0.3%	0.3%
90-150	11	0.4%	0.4%
90-180	12	0.5%	0.5%
0-180	2565	100.0%	100.0%

Electrical				
120V: P(W), I(A), THD(%), PF	28.4	0.238	8.0	0.994
277V: P(W), I(A), THD(%), PF	28.4	0.107	11.6	0.962
347V: P(W), I(A), THD(%), PF	N/A	N/A	N/A	N/A

AVG LUMINANCE (cd/m²)			
	0	45	90
0	8509	8509	8509
5	8572	8613	8664
15	8998	9438	9879
25	9635	10585	11468
35	9831	10499	10919
45	8610	8381	8151
55	6905	6570	6517
65	5561	5513	5705
75	3757	3836	3953
85	2092	2441	2441

