

## KT-PLED40-14-8XX-VDIM /G2

### LED PANEL LIGHT

#### DESCRIPTION

1'x4' LED panel light, 40W family, 120-277V input, 0-10V dimming



**5 YEAR**  
WARRANTY



#### PRODUCT FEATURES

- Aluminum frame featuring stepped edge design detail and gloss white paint for improved aesthetics
- Low profile architectural grade design
- Fits standard T-grid ceilings
- Suitable for surface or suspension mount with optional accessories
- High quality laser etched acrylic based light guide plate offers optimal light diffusion with no risk of yellowing over product lifetime
- Powered by Keystone 0-10V dimming LED driver with built-in junction box
- Compatible with Keystone SmartSafe emergency LED drivers; KT-EMRG-LED-5-500-EN /DF or KT-EMRG-LED-12-1200-EN /DF are optimal for fixture level installation; mounting kit KT-PLED-EM-BR-KIT required (sold separately)
- 50,000 hour rated life
- Over 50% energy savings as compared to traditional fluorescent troffers
- LED color binning within 4 SDCM ensures supreme color consistency between all panels
- Operating temperature range: -20°C/-4°F to 40°C/104°F
- Suitable for damp locations

#### PERFORMANCE SPECIFICATIONS

Catalog Number	Input Voltage	Wattage	Color Temperature	Lumen Output	CRI	Power Factor	Efficacy	Lifetime
KT-PLED40-14-835-VDIM /G2	120-277V	40W	3500K	4,050	>82.0	>0.9	101 lm/W	50,000 Hours
KT-PLED40-14-840-VDIM /G2	120-277V	40W	4000K	4,100	>82.0	>0.9	103 lm/W	50,000 Hours
KT-PLED40-14-850-VDIM /G2	120-277V	40W	5000K	4,150	>82.0	>0.9	104 lm/W	50,000 Hours

#### PHOTOMETRIC SPECIFICATIONS

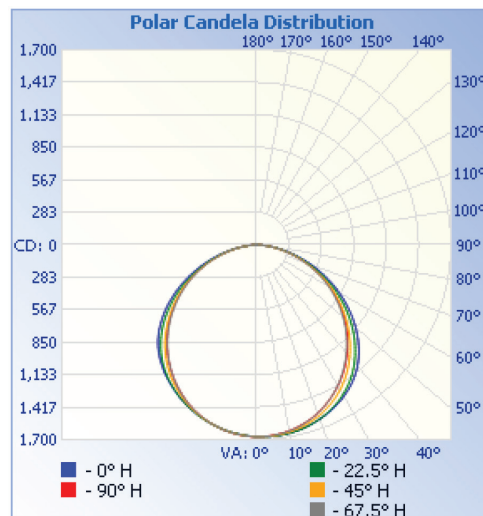
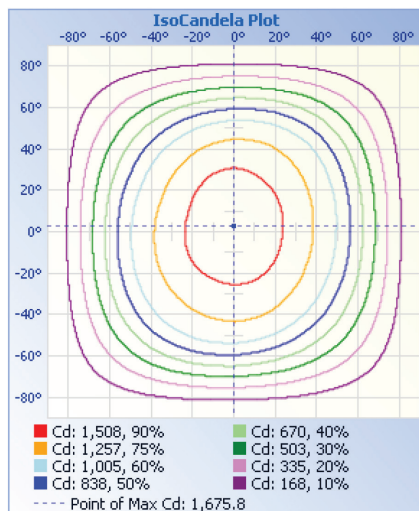

Zonal Lumen Summary		
Zone	Lumens	% Luminaire
0-30	1,313.9	26.5%
0-40	2,169.6	43.7%
0-60	3,892.4	78.5%
60-90	1,066.6	21.5%
70-100	443.3	8.9%
90-120	0.7	0%
0-90	4,959.0	100%
90-180	2.2	0%
0-180	4,961.2	100%



# KT-PLED40-14-8XX-VDIM /G2

## LED PANEL LIGHT

### PHYSICAL SPECIFICATIONS

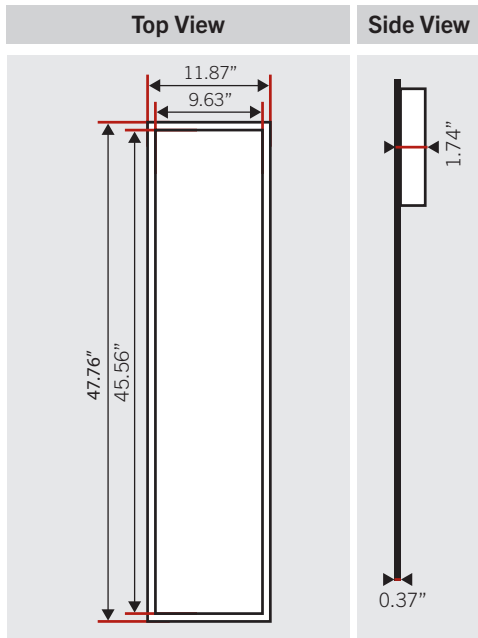

### WEIGHT INFORMATION

<b>1 Piece</b>	<b>1 Carton</b>
7.94 lbs	18.41 lbs

### ACCESSORIES (SOLD SEPARATELY)

Accessory	Catalog Number	Description
Cable Hanging Kit	KT-PLED-CABLE-KIT	Cable hanging kit for LED panel lights (includes 3 cable sets)
Surface Mount Kit	KT-PLED-SM-14-KIT	Surface mount kit for (1) 1x4 LED panel light
SmartSafe Emergency Battery Backup	KT-EMRG-LED-5-500-EN /DF	5W, 500 lumen SmartSafe emergency battery back-up with dual flex cables
	KT-EMRG-LED-12-1200-EN /DF	12W, 1200 lumen SmartSafe emergency battery back-up with dual flex cables for remote mounting only
Emergency LED Backup Mounting Kit	KT-PLED-EM-BR-KIT	Bracket kit for mounting emergency LED backup to LED panel lights; designed for use with KT-EMRG-LED-5-500-EN /DF and KT-EMRG-LED-12-1200-EN /DF

### ORDERING INFORMATION

ORDER CODE	PACK QUANTITY	UPC	EASY CODE	DLC PRODUCT ID
KT-PLED40-14-835-VDIM /G2-CP	TBD	843654111421	TBD	PFO2JCLS
KT-PLED40-14-840-VDIM /G2-CP	TBD	843654111438	YAU-81	PM34SCP6
KT-PLED40-14-850-VDIM /G2-CP	TBD	843654111445	RMK-17	PPM756SJ

### CATALOG NUMBER BREAKDOWN

# KT-PLED40-14-8XX-VDIM /G2

1      2      3      4      5      6      7      8

- 1 Keystone Technologies      5 80 CRI
- 2 Panel Light LED Fixture      6 Color Temperature
- 3 Wattage      7 0-10V Dimming
- 4 1' x 4' Nominal Size      8 Second Generation