



# KTS-PIR2-UV-KO

## PASSIVE INFRARED OCCUPANCY SENSOR

### DESCRIPTION

High Bay Passive Infrared Occupancy Sensor | For Use with High Bay Fixtures



**INPUT VOLTAGE:** 120/277/347Vac  $\pm$  10%

**FREQUENCY:** 50/60 Hz

**OUTPUT VOLTAGE:** 1–6V

**DIMMING:** 0–10V

**WARRANTY:** 5 Years



### PRODUCT FEATURES

- Fixture- or electrical box-mounted Passive Infrared Occupancy Sensor
- Interchangeable lens trim rings:
  - 360-degree High Bay Lens (white color trim ring): installed at the factory
  - Aisle Lens (black color trim ring): packed separately
- 20 ft. to 40 ft. mounting heights
- Four levels of output for dimming control
- Adjustable time delay and stand-by period
- Adjustable photocell sensitivity
- LED for activity indication
- UL Listed

### ELECTRICAL SPECIFICATIONS

Input Voltage Range	120/277/347Vac $\pm$ 10%
Frequency	50/60 Hz
Max. Load	800VA @ 120V; 1200VA @ 277V; 1500VA @ 347V
Max. Input Current	6.7A @ 120V; 4.3A @ 277V; 4.3A @ 347V
Power Consumption	$\leq$ 0.8W @ 120V; $\leq$ 1.6W @ 277V; $\leq$ 2.2W @ 347V

### DETECTION AND CONTROL

Detection Area	360° High Bay Lens (white) for diameter 60'; Aisle High Bay Lens (black) for 20' $\times$ 60'
Photocell Sensitivity	1 to $\infty$ Lux adjustable (LUX control knob)
Time Delay	30 sec. to 30 min. adjustable (TIME DELAY control knob)
Stand-by Period	30 sec. to 30 min. adjustable (STAND-BY PERIOD control knob)
Stand-by Dim Level	1V, 3V, 5V, 6V adjustable (DIP switch)
Dimming Type	0–10V dimming

### ENVIRONMENTAL SPECIFICATIONS

Operating Temperature	–10°C/14°F to 60°C/140°F
Storage Temperature	–20°C/–4°F to 85°C/185°F
Humidity	20% to 90% (non-condensing)
MTBF	TBD
Life Rating	TBD
Maximum Case Temperature	75°C/167°F



# KTS-PIR2-UV-KO

## PASSIVE INFRARED OCCUPANCY SENSOR

### PHYSICAL SPECIFICATIONS

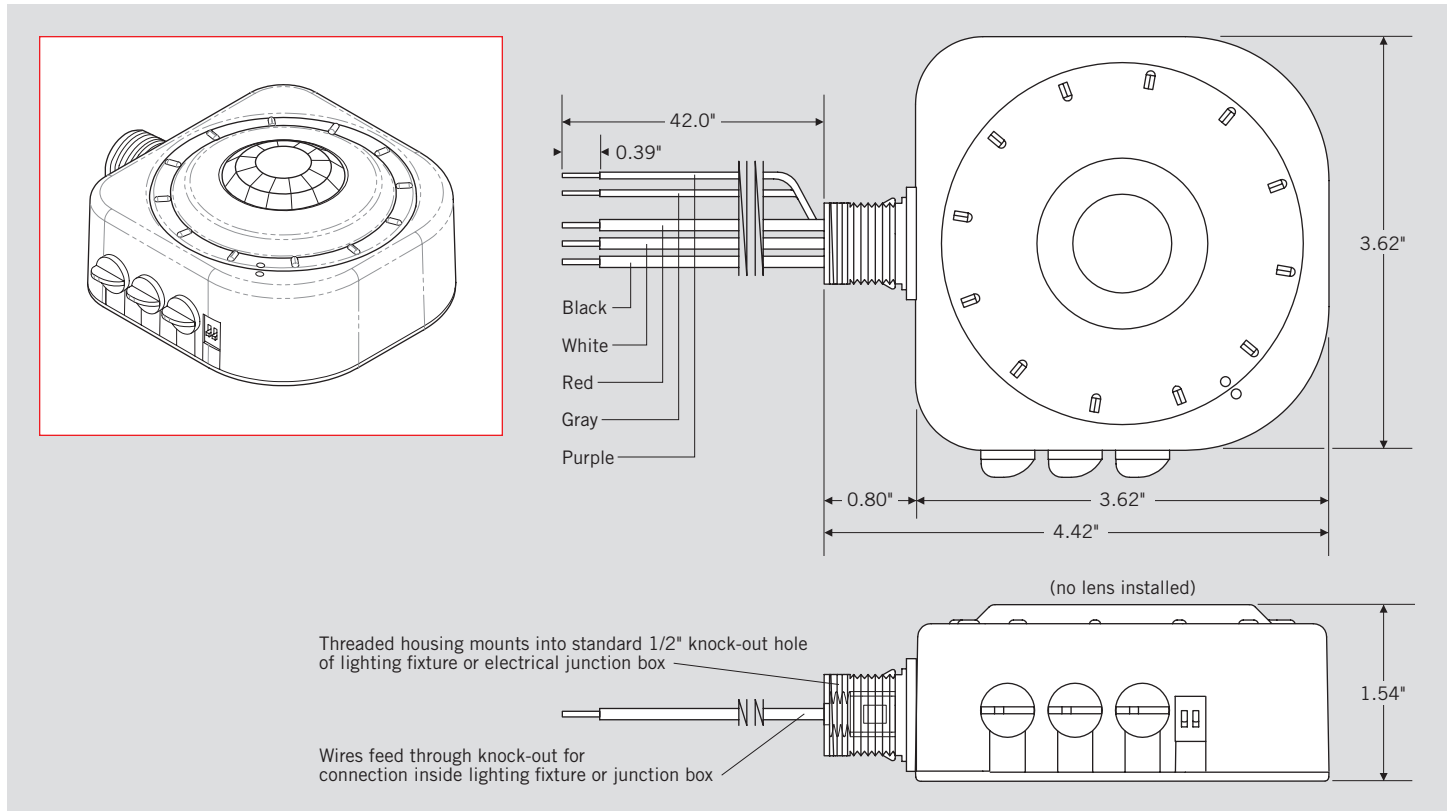

### WIRING SPECIFICATIONS

Input/Output	Black	42", UL 1316 #18AWG
	White	42", UL 1316 #18AWG
	Red	42", UL 1316 #18AWG
Dimming	Purple	42", UL 1569 #22AWG
	Gray	42", UL 1569 #22AWG

### WIRING DIAGRAMS

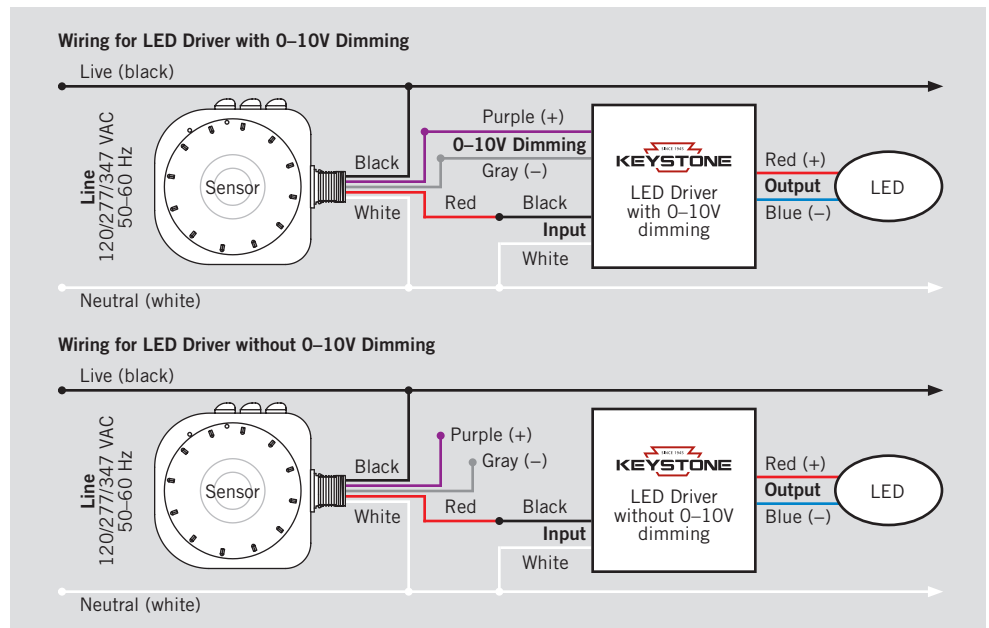

# KTS-PIR2-UV-KO

## PASSIVE INFRARED OCCUPANCY SENSOR

### INSTALLATION

**Warning:** Install/use in accordance with appropriate electrical codes and regulations.

**Warning:** If you are not sure about any part of these instructions, consult a qualified electrician.

**Warning:** Controlling a load in excess of the specified ratings will damage the unit and pose risk of fire, electric shock, personal injury, or death. Check your load ratings to determine the unit's suitability for your application.

**Warning:** To avoid fire, shock, or death, turn off power at circuit breaker or fuse box and test to ensure that the power is off before wiring. Installation without cutting power may also cause sensor malfunction.

#### Cautions:

- Disconnect power when servicing luminaire or changing bulbs.
- Use this device with copper or copper-clad wire only. With aluminum wire, use devices marked CO/ALR or CU/AL only.
- Do not attempt to disassemble or repair.
- Clean outer surface with a damp cloth only.

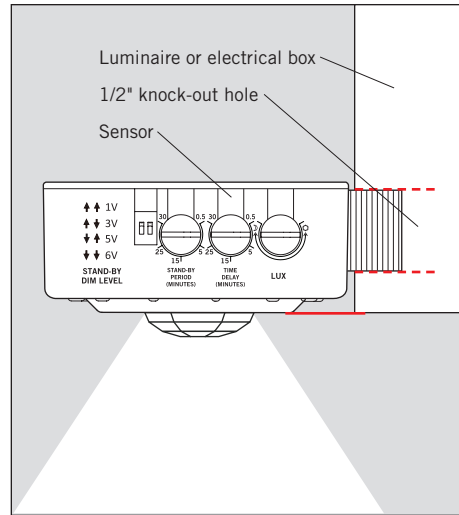

The sensor mounts in a 1/2" knock-out hole on the side of a luminaire or electrical box. The sensor's field-of-view may be partially obstructed by the luminaire housing. If the bottom of the sensor is mounted within 1" from the bottom of the housing, the field-of-view will not be affected.

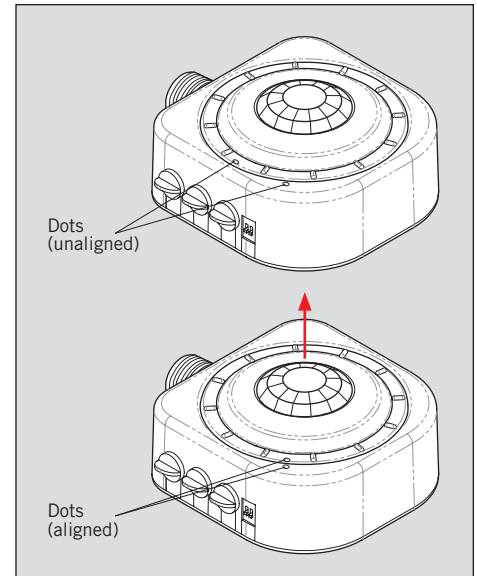

1. To change the lens for use in aisle applications, turn factory-installed trim ring so that the two indented dots line up, and then pull out trim ring using the finger tabs.

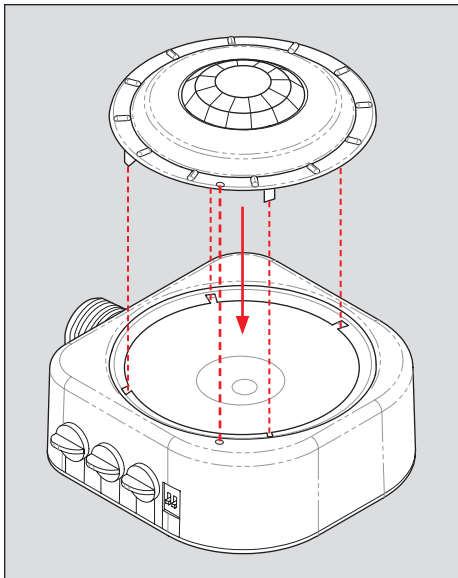

2. Line up the indented dots and indented tabs on underside of the black aisle lens, insert lens into sensor key openings, and turn lens clockwise.

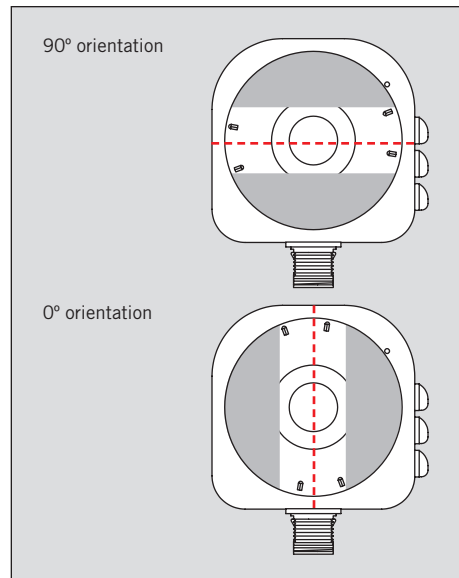

3. Align the finger tabs in the same direction as the aisle orientation. The lens will snap into indentation bumps, indicating that the lens direction is at either a 90° or 0° orientation.

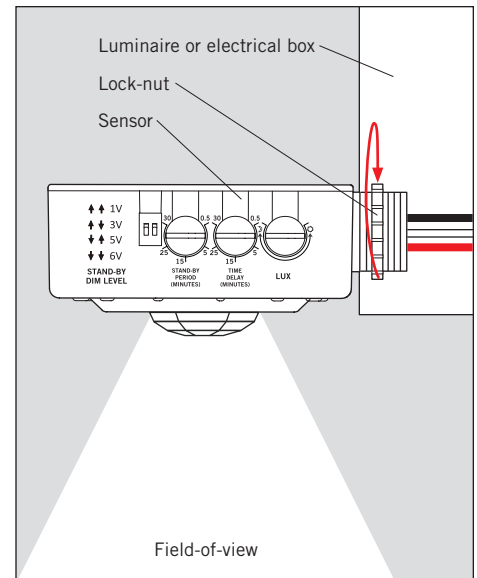

4. Remove the lock-nut from the threaded nipple and insert the wires and the threaded nipple into a half-inch hole of the luminaire body or the electrical box.
5. From inside the housing, slide the provided lock-nut over the wires and turn clockwise onto the threaded nipple to secure the sensor firmly in place. Ensure that the lens is orientated towards the area to be monitored (field-of-view).

(continued)



# KTS-PIR2-UV-KO

## PASSIVE INFRARED OCCUPANCY SENSOR

### INSTALLATION *(Continued)*

6. Connect wires per wiring diagrams on page 2: Black lead to Line (Live); Red lead to Load; White lead to Line (Neutral). Twist strands of each lead tightly and, using circuit conductors, push firmly into the appropriate wire connector. Screw connector on clockwise making sure that no bare wire shows below the connector. For dimmed output and stand-by period control, connect dimming control wire Purple to 0–10V dim (+) and Gray to 0–10V dim (-). Cap off any unused wires.
7. Restore power at circuit breaker or fuse.  
 Allow approximately 2 minutes for charge-up. If the lights turn ON and the LED blinks when a hand is waved in front of the lens, then the sensor has been installed properly.

### FIELD-OF-VIEW LENS OPTIONS

360° High Bay Lens (factory installed)

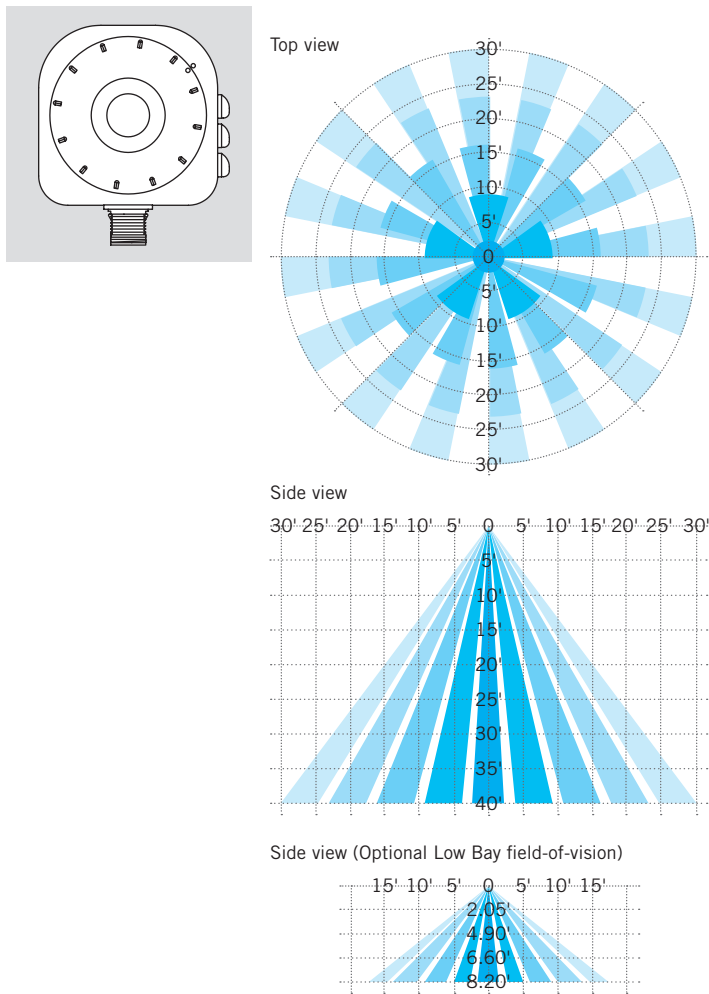

Aisle Lens

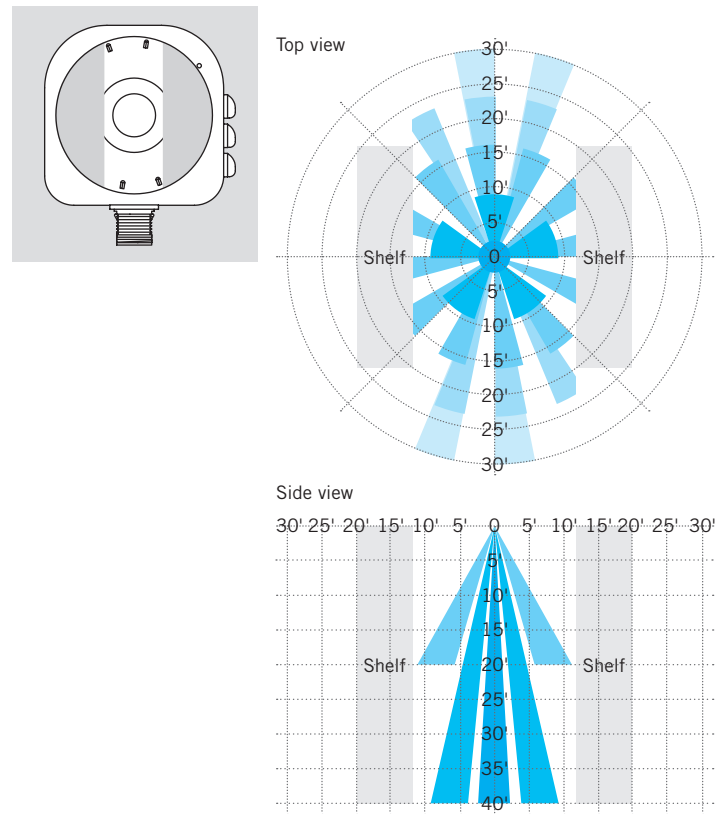

*Note:* Warehouse ambient temperature variations may affect sensor detection and coverage areas. For high-mount sensors, take into account the temperature at the coverage location. High temperatures (above 89–92°F) at the covered area reduce the sensor's field-of-view and may require installation of additional sensors. Additionally, with a high floor-level temperature, a sensor mounted higher than 40 feet may detect movement of only large objects (e.g., forklift trucks).



# KTS-PIR2-UV-KO

## PASSIVE INFRARED OCCUPANCY SENSOR

### SENSOR SETTINGS

Setting	Function	Range
<b>Lux</b>	Controls the light level at which the sensor will switch ON the lights when movement is detected.	Maximum ⚙️: Sensor will switch ON the light during most lighting conditions from darkness to sunlight. Minimum ⏸️: Sensor will operate only at dusk or in darker lighting conditions. Adjust the Lux control so that the sensor will work in any light level from ~30 Lux to ~2500 Lux by moving the control toward ⚙️.
<b>Time Delay</b>	Controls the amount of time the lights stay ON after the last detected movement.	30 seconds to 30 minutes.
<b>Stand-by Period</b>	Controls the amount of time for dimmed light output after Time Delay period.	30 seconds to 30 minutes.
<b>Stand-by Dim Level</b>	Controls fixture dimming to max lighting output.	1V (~10% of max output, driver-dependent) 3V (~30% of max output, driver-dependent) 5V (~50% of max output, driver-dependent) 6V (~60% of max output, driver-dependent)

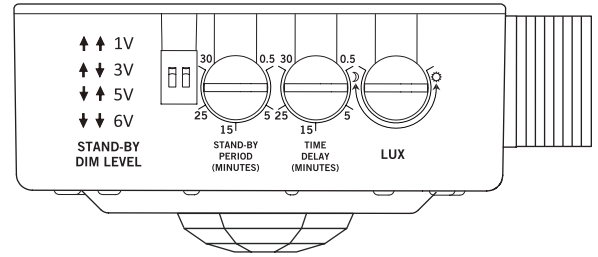

*Note: Settings should be determined during the installation period. After power is turned ON, wait at least 1 minute for normal operation to begin. If no dimming wires are connected, the LED driver or ballast will turn OFF after total Time Delay + Stand-by Period.*

### FUNCTION

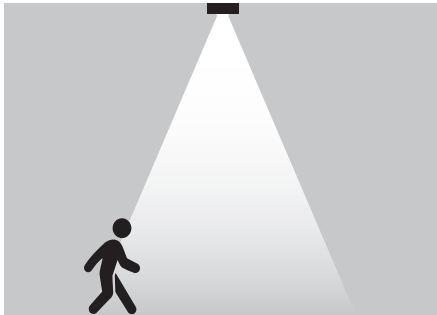

When motion is detected, lighting will turn on and remain at maximum lux setting brightness until motion is no longer detected for duration of time delay.

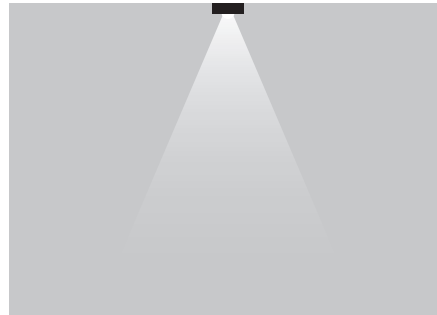

With dimming wires connected: If no further motion is detected after duration of time delay, lighting will dim and remain dimmed for duration of stand-by period.

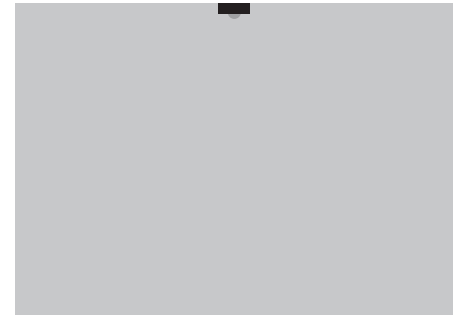

With no dimming wires connected: If no further motion is detected after combined duration of time delay and stand-by period, lighting will turn OFF.

### ORDERING INFORMATION

ORDER CODE	DESCRIPTION	PACK QUANTITY	EASY CODE	UPC
KTS-PIR2-UV-KO-CP	Passive Infrared Occupancy Sensor	20	I0F-04	843654123288

### CATALOG NUMBER BREAKDOWN

# KTS-PIR2-UV-KO

- 1** Keystone Technologies Sensor
- 2** Passive Infrared Occupancy Sensor Form Factor
- 3** Input Voltage: 120–277V
- 4** Knock-Out Mounting